

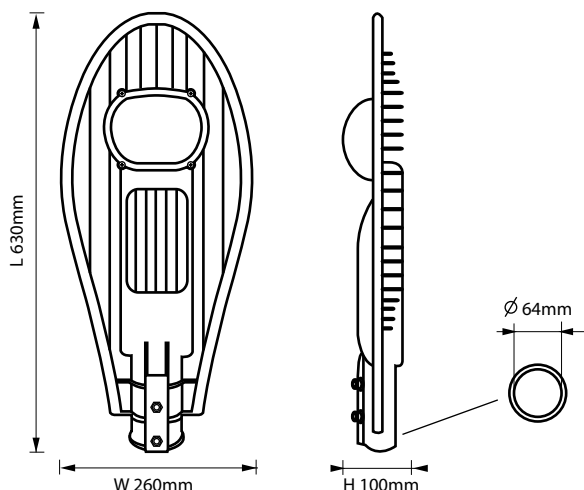

Luxtron STLA221L GEN 2



DIMENSIONS



INTENDED USE

The STLA221L Series LED luminaire provides uncompromising optical performance and outstanding versatility for a wide variety of area and compound lighting applications. Luxtron high power SMT LED engine technology delivers reliable uniform and energy-conscious illumination to walkways, parking lots, commercial and garden.

CONSTRUCTION AND OPTICS

Heavy-duty cast aluminum housing with polyester powder coat paint for superior protection against fade and wear. Offered standard in 4000K & 5700K (+/- 275K) CCT and nominal 70 CRI.

LED drivers hard mounted to die-cast aluminum back casting for optimal heat sinking and operation efficiency. Thermal management incorporates both conduction and natural convection to transfer heat rapidly away from the LED source and retain optimal efficiency and light output.

LINE DRAWING

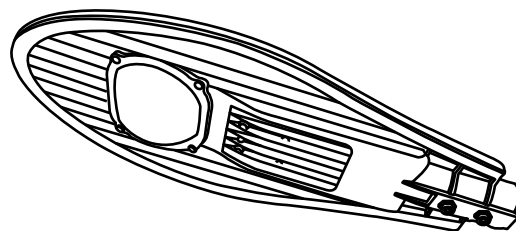

DIMENSION OF FITTING

Model	Wattage	Lumens	Weight kg	Replacement
STLA221LG2070-40	71W	9940 lm	3.18	SON 150W
STLA221LG2070-57	71W	9940 lm	3.18	SON 150W
STLA221LG2090-40	88W	12320 lm	3.90	SON 250W
STLA221LG2090-57	88W	12320 lm	3.90	SON 250W

ORDERING INFORMATION Lead times will vary based on options selected. Consult with your sales representative.
Example: STLA221LG2070-40

Type	Color Fitting	LED	Wattage	CCTK
Streetlight STLA221L	B Blue	(blank)	070 71w	-30 3000K
	W White	2	090 88w	-40 4000K
	G Dark Grey			-57 5700K

Powered by:

PHILIPS

Specifications and dimension subject to change without notice



HBL[®]
HI-BEAM™ Lighting

Carton : Dimension and Weight

Model	Standard Pack	Length (cm) per ctn	Width (cm) per ctn	Height (cm) per ctn	Gross Weight (kg/ctn)	Net Weight (kg/pc)
STLA221LG2070-40	1pc/ctn	67	31	15	3.79	3.18
STLA221LG2070-57	1pc/ctn	67	31	15	3.79	3.18
STLA221LG2090-40	1pc/ctn	67	31	15	4.51	3.90
STLA221LG2090-57	1pc/ctn	67	31	15	4.51	3.90